



Pronektar
LE FRUIT DU BOIS







Products in the Pronektar range benefit from the **know-how of Tonnellerie Radoux**: its knowledge of oak, of its selection and maturation.

The wood used comes exclusively from **barrel quality oak**, and is free of bark and sapwood. It is dried naturally in the open air in our wood yard.

The products are toasted in a convection oven specifically developed by Pronektar, **toasting the wood to the heart** in a homogeneous and reproducible way.

Thanks to our **ultra-modern production unit** located in the heart of the Brenne natural park, we can guarantee reproducibility and optimum quality for our products.

Our **R&D work** is carried out in close cooperation with research institutes all over the world. This enables us to offer a wide range of chips, staves, blocks and barrel inserts which satisfies the winemakers' technical and enological requirements to enhance wines matching with consumers' expectations.

TONNELLERIE RADOUX'S EXCLUSIVE KNOW-HOW IN SELECTING AND MATURING WOOD



AN ULTRA MODERN PRODUCTION UNIT



R&D CARRIED OUT WITH SUPPORT OF AN INTERNATIONAL NETWORK OF RESEARCHERS



AN EXCLUSIVE PROCESS, RESULTING IN A HOMOGENEOUS, REPRODUCIBLE TOAST TO THE HEART OF THE WOOD



BARREL QUALITY OAK, FREE OF BARK AND SAPWOOD



A BRAND OF THE RADOUX GROUP



CHIPS & GRANULATES

Nektar **FRESH**

Enological tool for vinification /
Fresh granulates with concentrated tannic content

Nektar **DUO FRESH**

Specific blend of both fresh and toasted granulates for vinification /
Complexity, sweetness, organoleptic corrections

Nektar **DOLCE VANILLA**

Specific blend of chips for a complex, vanilla result

Nektar **DOLCE MOKA**

Specific blend of chips for an intense and roasted result

TOASTED Granulates & Chips

All the quality of Pronektar within a full range dedicated to vinification and aging

Nektar **PURE VAN** NEW

Purity and intensity of vanilla
The benchmark on the vanilla chips market

LEGEND RECOMMENDED DOSE RATES

- | | |
|--|---|
|  Varietal and delicate white and rosé wines |  Powerful and concentrated red wines |
|  Rich and concentrated white wines |  Sweet and fortified wines |
|  Smooth and fruity red wines |  Spirits |



Enological tool for vinification
Fresh granulates with concentrated tannic content

PROPERTIES

- > 100% untoasted French oak granulates for vinification.
- > Barrel quality oak, natural aging in the wood yard, Oakscan® selection of wood with high content of ellagitannins, dehydrated before packing. Unique product on the market, highly concentrated.
- > Enhances the fruit character and softens the vegetal characteristics without adding any oak aroma. Brings structure, volume, sweetness. Early stabilization of the color, protection against oxidation.

OBJECTIVE: bring structure and sweetness, stabilize the color and protect the must during vinification.

TECHNICAL
CHARACTERISTICS

-  French oak
-  Dehydrated without toasting
-  10 kg (22 lbs) bag without mesh bag, box pallet of 300 kg (660 lbs)

GUIDELINES
FOR USE

OPTIMAL PERIOD FOR STARTING CONTACT

- White wines:
Just after the clarification of the must to obtain maximum protection of the freshness.
- Red wines:
While putting the harvested grapes in tank to benefit as quickly as possible from the protection against oxidation and stabilization of color.

SET UP

Use in mesh bags for white and rosé wines, and loose in the tank for red wines.

RECOMMENDED TIME OF CONTACT

Minimum 2 weeks, during the vinification period.

RECOMMENDED DOSE RATES

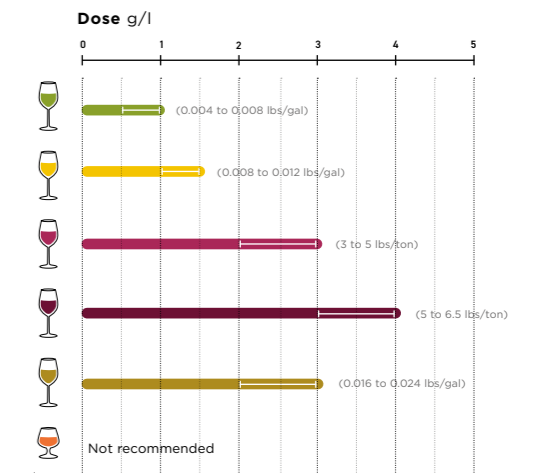

See legend page 07

PRACTICAL
EXAMPLES OF USE

On Sauvignon Blanc or Colombarid varietals, aiming for volume and length on the palate: 0.5 g/l (0.004 lbs/gal) just after the clarification of the must. Be careful not to overdose to avoid breaking down the varietal aromas.

On rich and structured Merlot, aiming for power and volume, with early stabilization of the color: 3 g/l (5 lbs/ton) while filling up the tank.

 In order to help you in your winemaking decisions, please contact your Pronektar technical support



Product Nektar Fresh
Dose 2.0 g/L
Oak contact Maceration and fermentation
Time of contact 15 days
Varietal Merlot
Vintage 2013
Geographic area Bordeaux, France

LEGEND:
--- Control
— Nektar Fresh

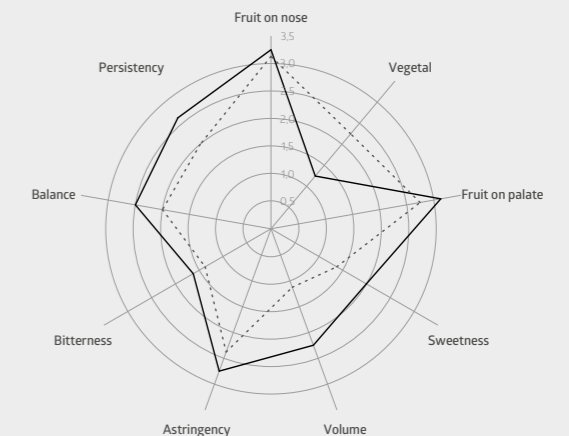

Nektar DUO FRESH

Specific blend of both fresh
and toasted granulates for vinification
Complexity, sweetness, organoleptic corrections



PROPERTIES

- > 100% French oak granulates for vinification, a specific recipe developed by Pronektar's R&D team.
- > More mature, complex fruit profile, better impact on the masking of vegetal and grassy character.
- > Higher contribution of volume and sweetness. Softening of harsh and astringent tannins linked to lack of maturity.

OBJECTIVE: benefit from the oenological advantages of fresh wood, while obtaining a more mature and softer profile.

TECHNICAL CHARACTERISTICS

 French oak

 Blend of dehydrated fresh granulates and toasted granulates

 10 kg (22 lbs) bag without mesh bag, carton box of 2 x 10 kg, pallet of 24 boxes

GUIDELINES FOR USE

OPTIMAL PERIOD FOR STARTING CONTACT

-White wines:

Just after the clarification of the must to obtain maximum protection of the freshness.

-Red wines:

While putting the harvested grapes in tank to benefit as quickly as possible from the protection against oxidation and stabilization of color.

SET UP

Use in mesh bags for white and rosé wines, and loose in the tank for red wines.

RECOMMENDED TIME OF CONTACT

Minimum 2 weeks, during the vinification period.

RECOMMENDED DOSE RATES



PRACTICAL EXAMPLES OF USE

On under-ripe Sémillon to mask the vegetal character and to bring fat and sweetness: 1 g/l (0.008 lbs/gal) just after the clarification of the must.

On a powerful Cabernet Sauvignon which lacks maturity, to mask the vegetal character of green peppers, bring volume and sweetness and soften the harsh tannins: 3 g/l (5 lbs/ton) while filling up the tank.



In order to help you in your winemaking decisions, please contact your Pronektar technical support

Product Nektar Duo Fresh
Dose 2.0 g/L
Oak contact Maceration and fermentation
Time of contact 15 days
Varietal Merlot
Vintage 2013
Geographic area Bordeaux, France

LEGEND:

--- Control
— Nektar Duo Fresh

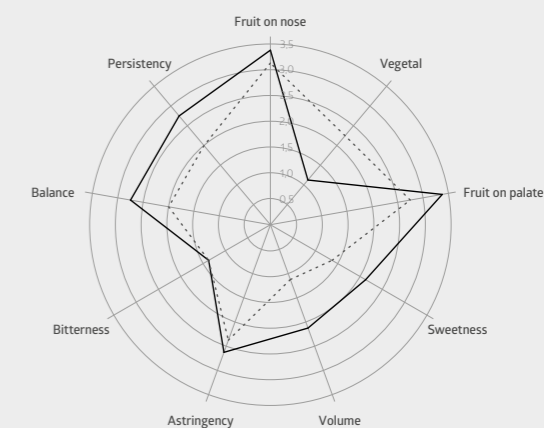

TOASTED Granulates & Chips

All the quality of Pronektar within a full range dedicated to vinification and aging

PROPERTIES

- > Oakscan® selection of wood with moderate level of ellagitannins, for a maximum aromatic expression and sweetness without any excess in structure.
- > Varied and typical aromatic profiles depending on the origin of the wood and the type of toast, volume and sweetness on the palate.
- > 2 sizes: granulates for vinification, chips for aging.

OBJECTIVE: obtain aromatic and pleasing oak profiles with effective contact periods, bringing a maximum of sweetness without any excess in structure.

TECHNICAL CHARACTERISTICS

 French oak or American oak

 Medium, Medium plus

 10 kg (22 lbs) bag (with mesh bag for chips only), carton box of 2 x 10 kg, pallet of 24 boxes

GUIDELINES FOR USE

OPTIMAL PERIOD FOR STARTING CONTACT

-White wines:

From start of primary fermentation to obtain a well-integrated oak profile and to respect the profile of the fruit.

-Red wines:

While putting the harvested grapes in tank for granulates. Chips, before malolactic fermentation for a more complex aromatic profile and a maximum integration of the tannic structure, or at beginning of aging.

RECOMMENDED AGING TEMPERATURE

15°C (60°F) minimum with strict monitoring of microbiological conditions.

SET UP

It is recommended that the bags be attached halfway up the tank, using food-grade binding straps.

RECOMMENDED TIME OF CONTACT

Minimum 2 weeks for granulates, minimum 1 month for chips, to be monitored by tasting.

RECOMMENDED DOSE RATES

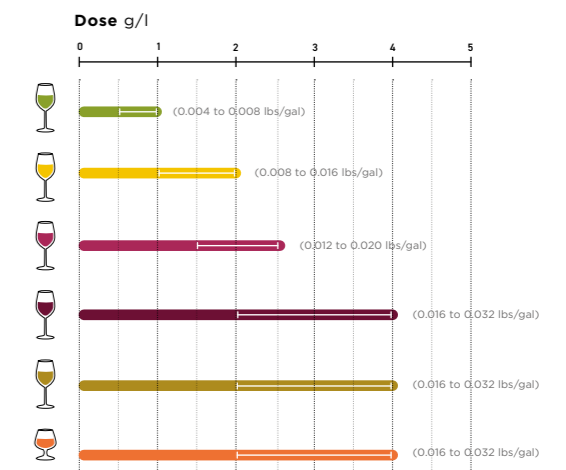

See legend page 07

PRACTICAL EXAMPLES OF USE

On quick-turnover Sauvignon Blanc, aiming for an aromatic, generous oak profile: Chips 1.5 g/l (0.012 lbs/gal), 2/3 American oak medium toast and 1/3 French oak medium plus toast at the start of primary fermentation.

On quick-turnover, smooth and fruity red wine, aiming for an improvement of the aromas and taste when preparing to bottle: Chips 2 g/l (0.016 lbs/gal), 1/3 French oak medium toast, 1/3 French oak medium plus toast, 1/3 American oak medium toast, 2 to 3 months before bottling.

 In order to help you in your winemaking decisions, please contact your Pronektar technical support

Product Pronektar French Oak Chips Medium toast
Dose 3,0 g/L
Oak contact Aging
Time of contact 6 months
Varietal Sangiovese
Vintage 2014
Geographic area Italy

LEGEND:

--- Control
 — Pronektar French Oak Chips Medium toast

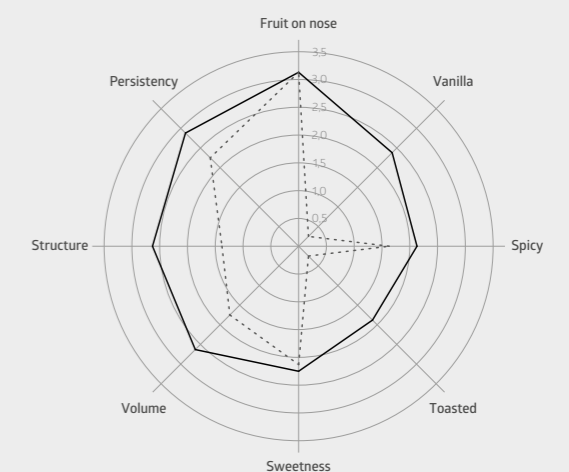

Nektar DOLCE VANILLA

Specific blend of chips
for a complex, vanilla result



PROPERTIES

- > Specific recipe of toasted chips developed for vinification and aging by the Pronekar R&D team.
- > Oak, vanilla, lactone, creamy notes with respect of the fruit profile.
- > Sweetness and volume on the palate.

OBJECTIVE: complex, vanilla oak profile, respecting the fruit. Volume and sweetness on the palate.

TECHNICAL CHARACTERISTICS

- Blend of French oak and American oak
- Blend of toasts
- 10 kg (22 lbs) bag with mesh bag, carton box of 2 x 10 kg, pallet of 24 boxes

GUIDELINES FOR USE

OPTIMAL PERIOD FOR STARTING CONTACT

- White wines:**
From start of primary fermentation to obtain a well-integrated oak profile and to respect the profile of the fruit.
- Red wines:**
Before malolactic fermentation for a more complex aromatic profile and maximum integration of the tannic structure, or at beginning of aging.

RECOMMENDED AGING TEMPERATURE

15°C (60°F) minimum with strict monitoring of microbiological conditions.

SET UP

It is recommended that the bags be attached halfway up the tank, using food-grade binding straps.

RECOMMENDED TIME OF CONTACT

Minimum 1 month, to be monitored by tasting.

PRACTICAL EXAMPLES OF USE

On delicate, elegant white wine, aiming for oak complexity and volume on the palate while respecting the fruit profile: 1 g/l (0.008 lbs/gal) at the start of primary fermentation.

On mature, balanced red wines, aiming for a vanilla, complex oak profile, with respect of the fruit, and with sweetness and volume on the palate: 2.5 g/l (0.020 lbs/gal) at the start of malolactic fermentation or during aging.

RECOMMENDED DOSE RATES

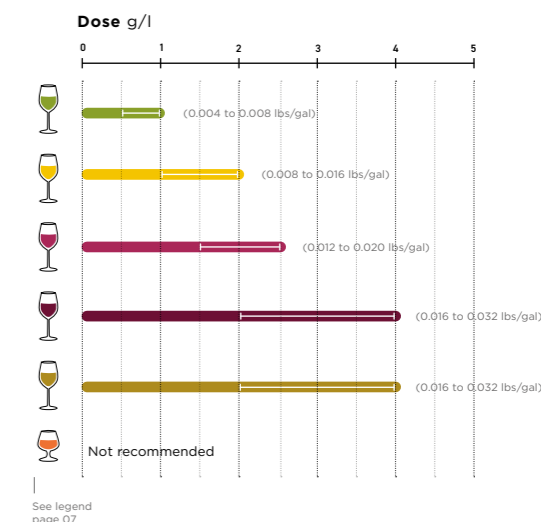

In order to help you in your winemaking decisions, please contact your Pronekar technical support

Product	Nektar Dolce Vanilla
Dose	2.2 g/L
Oak contact	Aging
Time of contact	6 weeks
Varietal	Tempranillo
Vintage	2013
Geographic area	Spain

LEGEND:
 - - - Control
 — Nektar Dolce Vanilla

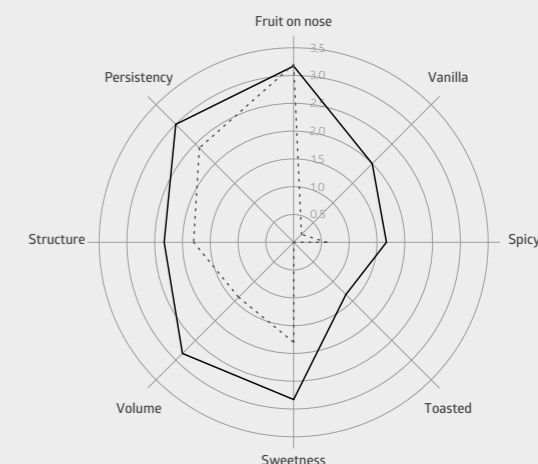

Nektar DOLCE MOKA

Specific blend of chips for an intense and roasted result



PROPERTIES

- > Specific recipe of toasted chips developed for vinification and aging by Pronektar's R&D team.
- > Roasted, dark chocolate, grilled oak notes.
- > Power and volume on the palate.

OBJECTIVE: toasted oak profile, power on the palate, aiming for intense oak profiles.

TECHNICAL CHARACTERISTICS

- French oak
- Specific
- 10 kg (22 lbs) bag with mesh bag, carton box of 2 x 10 kg, pallet of 24 boxes

GUIDELINES FOR USE

OPTIMAL PERIOD FOR STARTING CONTACT

- White wines:**
From start of primary fermentation to obtain a well-integrated oak profile and to respect the profile of the fruit.
- Red wines:**
Before malolactic fermentation for a more complex aromatic profile and a maximum integration of the tannic structure or right at the start of aging.

RECOMMENDED AGING TEMPERATURE

15°C (60°F) minimum with strict monitoring of microbiological conditions.

SET UP

It is recommended that the bags be attached halfway up the tank, using food-grade binding straps.

RECOMMENDED TIME OF CONTACT

Minimum 1 month, to be monitored by tasting.

RECOMMENDED DOSE RATES

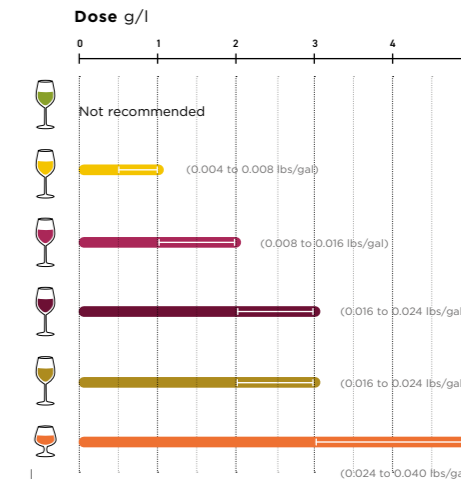

See legend page 07

PRACTICAL EXAMPLES OF USE

On mature, concentrated Mediterranean varietals (such as Tempranillo, Sangiovese), to enhance the dark fruit, bring power and chocolate and slightly roasted notes: 2 g/l (0.016 lbs/gal) at the start of malolactic fermentation or during aging.

On brandy, aiming for dark chocolate, roasted notes: 5 g/l (0.040 lbs/gal) during aging.



In order to help you in your winemaking decisions, please contact your Pronektar technical support

Product	Nektar Dolce Moka
Dose	2.2 g/L
Oak contact	Aging
Time of contact	6 weeks
Varietal	Tempranillo
Vintage	2013
Geographic area	Spain

LEGEND:
 - - - Control
 — Nektar Dolce Moka

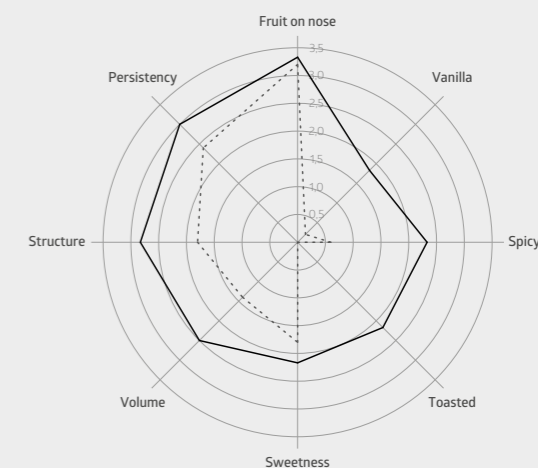

NEW

Nektar PURE VAN

Purity and intensity of vanilla
The benchmark on the vanilla chips market



PROPERTIES

- > French Oak chips toasted with a unique and innovative process.
- > Extremely pure and intense aromas of vanilla bean and vanilla sugar.

OBJECTIVE: The answer when seeking intense vanilla profile, with sweetness and low tannic impact on the palate.

TECHNICAL CHARACTERISTICS

- French oak
- Specific
- 10 kg (22 lbs) bag with mesh bag, carton box of 2 x 10 kg, pallet of 24 boxes

GUIDELINES FOR USE

OPTIMAL PERIOD FOR STARTING CONTACT

- White wines:**
From start of primary fermentation to obtain a well-integrated oak profile. During aging for a more intense profile.
- Red wines:**
Before malolactic fermentation to obtain a well-integrated oak profile. During aging for a more intense profile.

RECOMMENDED AGING TEMPERATURE

15°C (60°F) minimum with strict monitoring of microbiological conditions.

SET UP

It is recommended that the bags be attached halfway up the tank, using food-grade binding straps.

RECOMMENDED TIME OF CONTACT

Minimum 1 month, to be monitored by tasting.

RECOMMENDED DOSE RATES



CHEMICAL AND AROMATIC PROFILES

PureVan - Chemical profile

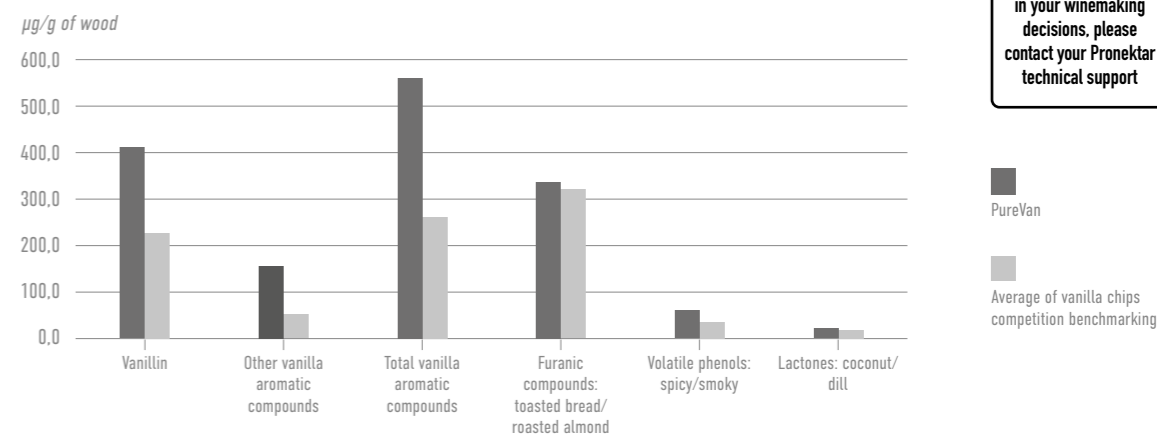

In order to help you in your winemaking decisions, please contact your Pronektar technical support

PureVan - Sensory profile

Product: PureVan
Dose: 5 g/l
Oak contact: Aging
Time of contact: 6 weeks
Varietal: Merlot
Vintage: 2023
Geographic area: France

LEGEND:
--- Control
— PureVan
..... Average of vanilla chips competition benchmarking

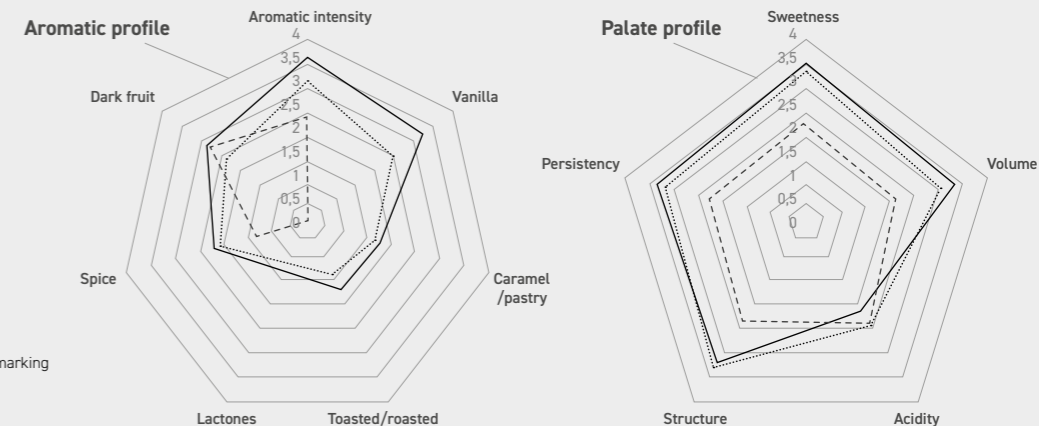

STAVES

Nektar **ESSENTIELLE**

Pronektar's historical reference /
Quality aging, controlled budget

7
mm

Nektar **EXCELLENCE**

Selection of tight grain /
Aging with elegance and softness

7
mm

Nektar **PURE**

Optimal respect of the fruit

7
mm

Nektar **EXTRÊME**

Total control of oak profile thanks
to the Oakscan® selection

7
mm

Nektar **FINESSE**

Pronektar expertise in fruit and terroir revelation /
Preserved aromatic typicity, roundness,
discrete tannic impact

7
mm

Nektar **XL**

Large dimension stave /
Aging over a long period

12
mm

Nektar **EXCLUSIVE**

The super-premium stave /
Dedicated to the aging of top-of-the-range wines

17
mm

LEGEND RECOMMENDED DOSE RATES



Varietal and delicate
white and rosé wines



Powerful and concentrated red wines



Rich and concentrated
white wines



Sweet and fortified wines



Smooth and fruity red wines



Spirits



Nektar ESSENTIELLE

Pronektar's historical reference
Quality aging, controlled budget



PROPERTIES

- > French oak or American oak staves.
- > Aromatic intensity, complexity, combining toasts and wood origins.
- > Structure and sweetness on the palate.

OBJECTIVE: generous, modern oak profiles.

TECHNICAL CHARACTERISTICS

- French oak or American oak
- +/- 200 g (0.44 lbs)
- 0.105m² (1.12 sq ft)
- Medium, Medium Plus
- Carton box of 100 staves, pallet of 25 boxes

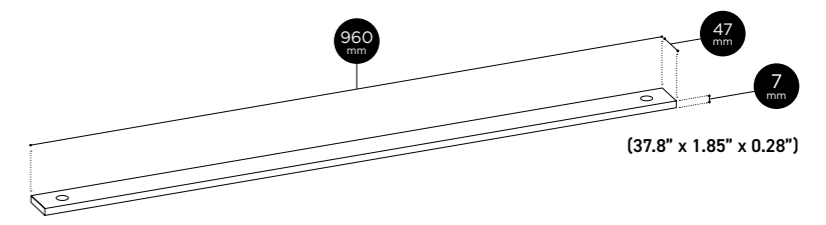

GUIDELINES FOR USE

OPTIMAL PERIOD FOR STARTING CONTACT

- White wines:**
From start of primary fermentation to obtain a well-integrated oak profile and respect the profile of the fruit.
- Red wines:**
Before malolactic fermentation to obtain a more complex aromatic profile and maximum integration of the tannic structure, or at the beginning of aging.

RECOMMENDED AGING TEMPERATURE

15°C (60°F) minimum with strict monitoring of microbiological conditions.

SET UP

It is recommended that the staves be attached halfway up the tank, using food-grade binding straps, or to stack them on stainless steel rods.

RECOMMENDED TIME OF CONTACT

Minimum 4 months, to be monitored by tasting.

RECOMMENDED DOSE RATES

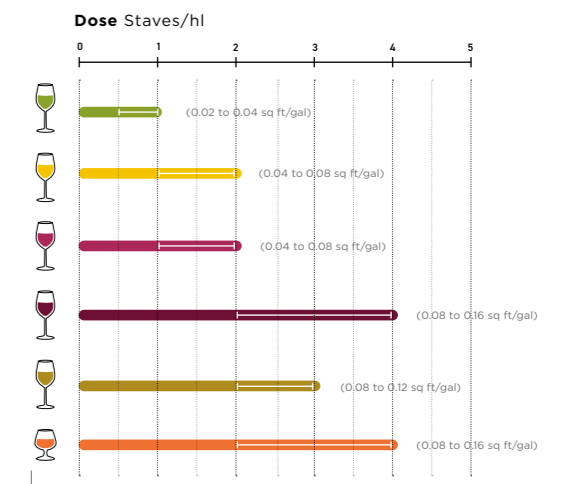

PRACTICAL EXAMPLES OF USE

On rich white varieties (Chardonnay, Gros Manseng, Marsanne, Roussanne), aiming for aromatic intensity and complexity: 2 staves/hl (0.08 sq ft/gal), 50% French oak medium toast, 50% French oak medium plus toast at the beginning of primary fermentation.

On structured Cabernet Sauvignon, aiming for aromatic oak and for ripening the fruit profile: 3 staves/hl (0.13 sq ft/gal), 1/3 French oak medium toast, 1/3 French oak medium plus toast, 1/3 American oak medium plus toast at start of malolactic fermentation or at beginning of aging.

In order to help you in your winemaking decisions, please contact your Pronektar technical support

Product Nektar Essentielle French Oak Medium and Medium + toast
Dose 2,8 stv/hL
Oak contact Aging
Time of contact 5,5 months
Varietal Merlot - Cabernet Sauvignon blend
Vintage 2010
Geographic area Languedoc, France

LEGEND:
 - - - Nektar Essentielle French Oak Medium
 — Nektar Essentielle French Oak Medium + toast

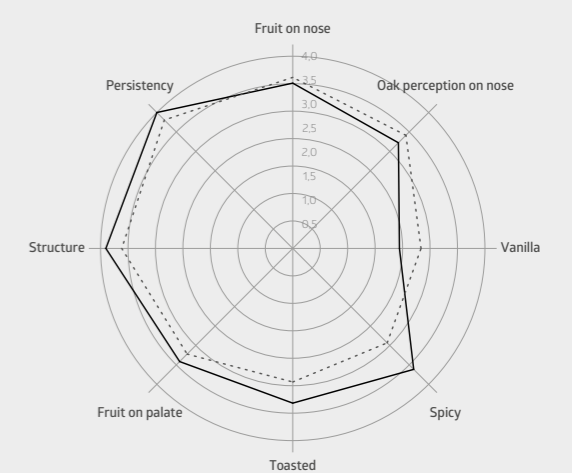

Nektar EXCELLENCE

Selection of tight grain
Aging with elegance and softness



PROPERTIES

- > French oak staves tight grain selection - size of grain < 2.5 mm (0.01").
- > Complexity and aromatic elegance.
- > Elegance of tannins and sweetness on the palate.

OBJECTIVE: fine and elegant oak profiles.

TECHNICAL CHARACTERISTICS

- French oak
- +/- 200 g (0.44 lbs)
- 0.105 m² (1.12 sq ft)
- Light, Medium, Medium Plus
- Carton box of 100 staves, pallet of 25 boxes

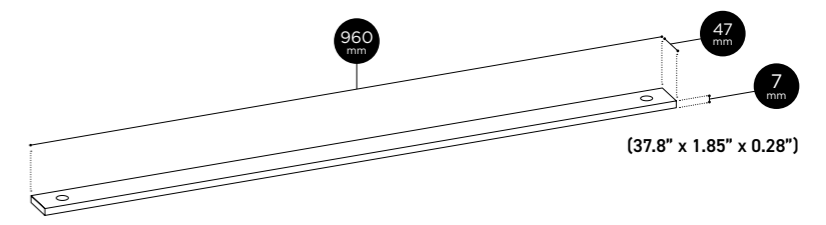

GUIDELINES FOR USE

OPTIMAL PERIOD FOR STARTING CONTACT

- White wines:**
From start of primary fermentation to obtain a well-integrated oak profile and respect the profile of the fruit.
- Red wines:**
Before malolactic fermentation to obtain a more complex aromatic profile and maximum integration of the tannic structure, or at the beginning of aging.

RECOMMENDED AGING TEMPERATURE

15°C (60°F) minimum with strict monitoring of microbiological conditions.

SET UP

It is recommended that the staves be attached halfway up the tank, using food-grade binding straps, or to stack them on stainless steel rods.

RECOMMENDED TIME OF CONTACT

Minimum 4 months, to be monitored by tasting.

PRACTICAL EXAMPLES OF USE

On concentrated white varietals at optimal maturity (Sauvignon Blanc, Sauvignon Gris, Verdejo), aiming for an elegant and complex oak profile similar to that obtained with traditional aging: 2 staves/hl (0.08 sq ft/gal), 1/3 light toast, 1/3 medium toast, 1/3 medium plus toast at the beginning of primary fermentation.

Be careful not to overdose, especially in the case of the light toast to avoid breaking down the varietal aromas.

On structured and concentrated Merlot, aiming for an intense oak profile with softness and elegance: 3 staves/hl (0.12 sq ft/gal), 50% medium toast, 50% medium plus toast at the start of malolactic fermentation or at the beginning of aging.

RECOMMENDED DOSE RATES



In order to help you in your winemaking decisions, please contact your Pronektar technical support

Product	Nektar Excellence Medium toast
Dose	3,0 stv/hl
Oak contact	Aging
Time of contact	4,5 months
Varietal	Merlot
Vintage	2007
Geographic area	Italy

LEGEND:
 - - - Nektar Essentielle Medium toast
 — Nektar Excellence Medium toast

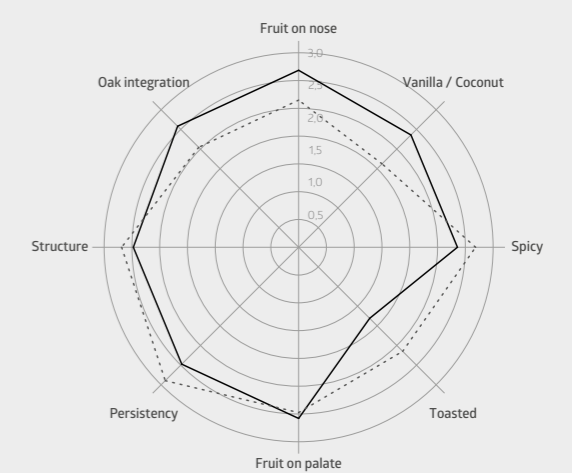

Optimal respect of the fruit



PROPERTIES

- > French oak staves with a unique and specific toast.
- > Total respect of the pure expression of the fruit, minimum contribution of toasted aromas.
- > Build-up of structure, sweetness, freshness and persistency on the palate.

OBJECTIVE: the benefits of the oak contribution on the palate without the aromatic impact from the toast.

7
mmTECHNICAL
CHARACTERISTICS

- French oak
- +/- 200 g (0.44 lbs)
- 0.105 m² (1.12 sq ft)
- Specific
- Carton box of 100 staves, pallet of 25 boxes

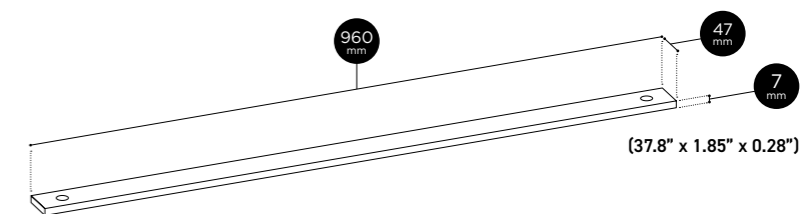
GUIDELINES
FOR USE

OPTIMAL PERIOD FOR STARTING CONTACT

-White wines:

From start of primary fermentation to obtain a well-integrated oak profile.

-Red wines:

Before malolactic fermentation to obtain maximum integration of the tannic structure.

RECOMMENDED AGING TEMPERATURE

15°C (60°F) minimum with strict monitoring of microbiological conditions.

SET UP

It is recommended that the staves be attached halfway up the tank, using food-grade binding straps, or to stack them on stainless steel rods.

RECOMMENDED TIME OF CONTACT

Minimum 4 months, to be monitored by tasting.

PRACTICAL
EXAMPLES OF USE

On white wines, amylic style (Sémillon, Grenache Blanc, Vermentino), with the aim of reinforcing the volume, freshness and persistency on the palate, without contributing any oak aromas: 1 stave/hl (0.04 sq ft/gal) at the start of primary fermentation.

On over-mature and/or slightly faded Merlot, with the aim of refreshing the fruit profile and regaining freshness and balance on the palate by covering the dry tannins: 2 staves/hl (0.08 sq ft/gal) when racking off the skins.

RECOMMENDED DOSE RATES

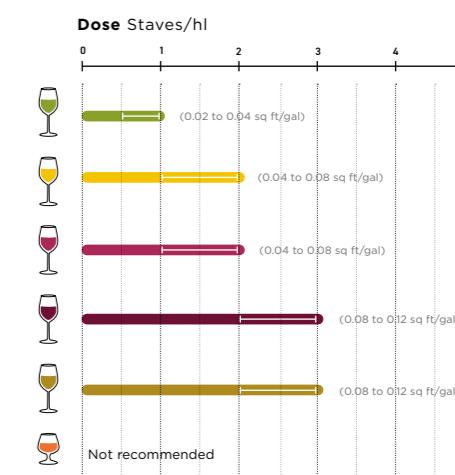

See legend page 19



In order to help you in your winemaking decisions, please contact your Pronektar technical support

Product	Nektar Pure
Dose	3.0 stv/hL
Oak contact	Malolactic fermentation
Time of contact	6 months
Varietal	Merlot - Cabernet Sauvignon blend
Vintage	2009
Geographic area	Bordeaux, France

LEGEND:

- Control
- Nektar Pure
- Nektar Essentielle French Oak Medium + toast

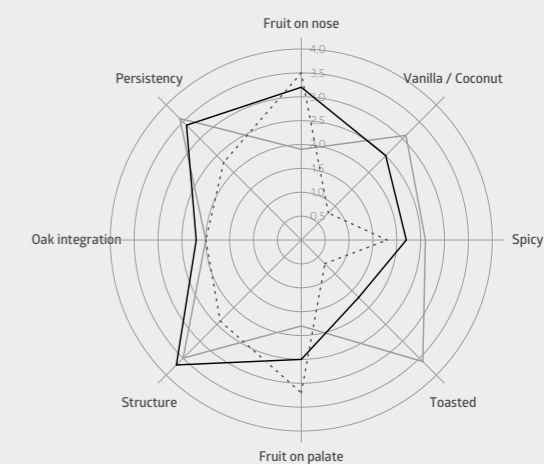

Nektar EXTRÊME

Total control of oak profile
thanks to the Oakscan® selection





7
mm

PROPERTIES

- > French oak staves selected with the Oakscan® process.
- > Three products, each with a specific level of tannin content: low, medium or high.
- > A specific toast adapted to each tannin content level.

OBJECTIVE: total control and perfect reproducibility of oak profiles.

TECHNICAL CHARACTERISTICS

-  French oak
-  +/- 200 g (0.44 lbs)
-  0.105 m² (1.12 sq ft)
-  Specific
-  Carton box of 100 staves,
pallet of 25 boxes

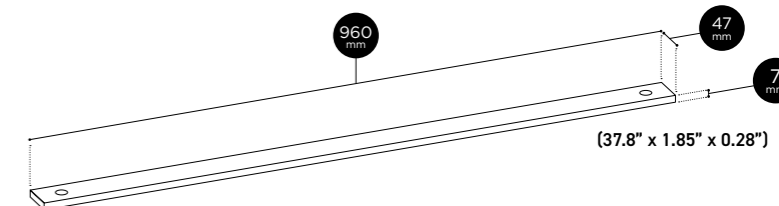

GUIDELINES FOR USE

OPTIMAL PERIOD FOR STARTING CONTACT

-White wines:

From the start of primary fermentation for a well-integrated oak profile and respect of the fruit.

-Red wines:

Before malolactic fermentation for a more complex aromatic profile and optimal integration of the tannic structure, or at the beginning of aging.

RECOMMENDED AGING TEMPERATURE

15°C (60°F) minimum with strict monitoring of microbiological conditions.

SET UP

It is recommended that the staves be attached halfway up the tank, using food-grade binding straps, or to stack them on stainless steel rods.

RECOMMENDED TIME OF CONTACT

Minimum 4 months, to be monitored by tasting.



In order to help you in your winemaking decisions, please contact your Pronektar technical support

PRACTICAL EXAMPLES OF USE

On fresh white grape varieties with a varietal profile such as Sauvignon Blanc, aiming for a very discreet oak profile, respect of the fruit, complexity and minerality: 1 stave/hl (0.04 sq ft/gal), 80% Extrême Délicat, 20% Extrême Intense at the start of primary -fermentation.

On mature and exotic white grape varieties such as Sauvignon Blanc, Sauvignon Gris, Verdejo, for a generous and complex oak profile, with volume and persistency on the palate:

1.5 stave/hl (0.06 sq ft/gal), 2/3 Extrême Délicat, 1/3 Extrême Complexe at the start of primary fermentation.

On Merlot with a fresh fruit profile, soft and fruity, aiming for additional sweetness and complexity: 2 staves/hl (0.08 sq ft/gal), 2/3 Extrême Délicat, 1/3 Extrême Complexe at start of malolactic fermentation or at beginning of aging.

On powerful and concentrated Cabernet Sauvignon, aiming for oak profile which will optimize the varietal aromatic profile and bring sweetness and power on the palate: 3 staves/hl (0.12 sq ft/gal), 1/3 Extrême Délicat, 2/3 Extrême Intense at start of malolactic fermentation or at beginning of aging.

On brandy, aiming for complexity and aromatic strength, chocolate and roasted notes, power and volume on the palate: 3 staves/hl (0.12 sq ft/gal), 50% Extrême Complexe, 50% Extrême Intense during aging.

Nektar EXTRÊME Delicat

PROPERTIES

- > Oakscan® selection : low tannin content.
- > Discreet and delicate aromatic contribution, vanilla, floral and sweet spices notes, respect of fruit.
- > Not too much structure on the palate, sweetness and roundness.

Objective: discreet oak profile with respect of fruit, contribution of sweetness without too much structure.

RECOMMENDED DOSE RATES

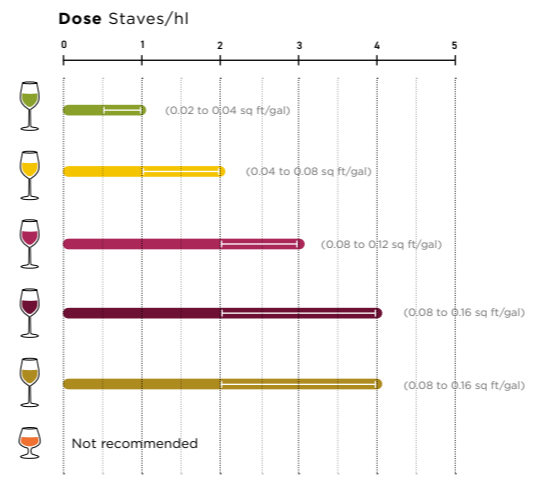

See legend page 19

MERLOT - CABERNET SAUVIGNON BLEND, DOSE: 3,2 STAVES/HL

Comments: Enhancement of aromatic profile with lactone, vanilla and spicy notes. Mouth improvement, with increase of roundness, structure and fullness. Improvement of persistency.

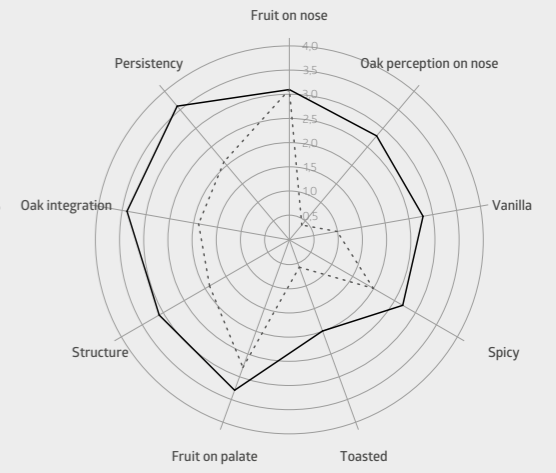

LEGEND:
- - - Control
— Nektar Extrême Delicat

Nektar EXTRÊME Complexe

PROPERTIES

- > Oakscan® selection: medium tannin content.
- > Wide and complex aromatic palette, roasted, spicy, vanilla notes.
- > Balanced structure on the palate, fullness and persistency.

Objective: balanced, complex oak profile, even when used by itself.

RECOMMENDED DOSE RATES



MERLOT - CABERNET SAUVIGNON BLEND, DOSE: 3,2 STAVES/HL

Comments: Clear aromatic impact on complexity, vanilla, spicy and toasted notes. Important mouth improvement, with increase of structure, fullness and persistency.

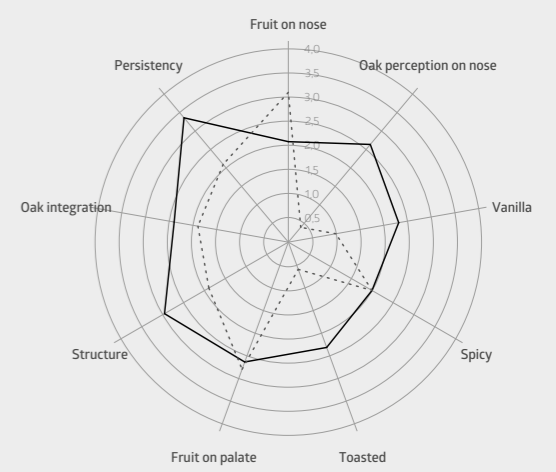

LEGEND:
- - - Control
— Nektar Extrême Complexe

Nektar EXTRÊME Intense

PROPERTIES

- > Oakscan® selection: high tannin content.
- > Intense contribution of aromas, roasted, dark chocolate, slightly smoked and mineral notes on white wines.
- > Structure on the palate but without excess thanks to a higher thermic treatment, volume and sweetness, persistency.

Objective: typical, intense oak profile, and excellent blending tool.

RECOMMENDED DOSE RATES

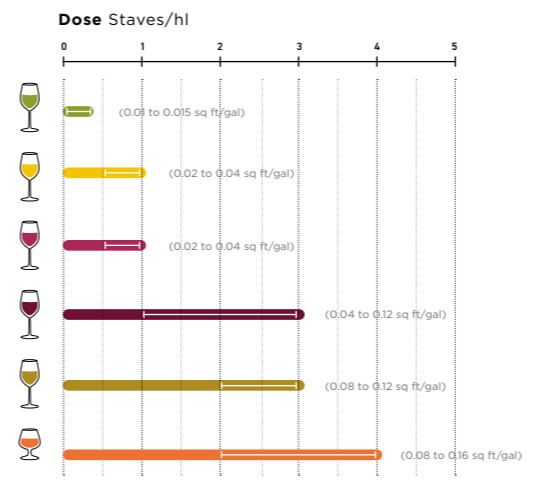

MERLOT - CABERNET SAUVIGNON BLEND, DOSE: 3,2 STAVES/HL

Comments: Strong aromatic impact, mainly on toasted, roasted and spicy notes. Important impact on structure, fullness and roundness.

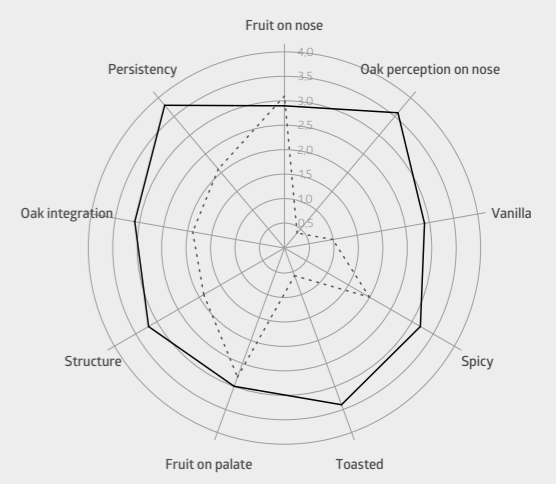

LEGEND:
- - - Control
— Nektar Extrême Intense

Nektar FINESSE

Pronektar expertise in fruit and terroir revelation
Preserved aromatic typicity, roundness, discrete tannic impact



PROPERTIES

- > French oak staves selected with the Oakscan® process.
- > Oakscan® low tannin content selection, unique and specific low temperature toast.
- > Total respect of aromatic fruit profile, softness and volume in the mouthfeel.

OBJECTIVE: Enhancement of the fruit and terroir, volume and roundness with discrete tannic impact.

7 mm

TECHNICAL CHARACTERISTICS

- French oak
- +/- 200 g (0.44 lbs)
- 0.105 m² (1.12 sq ft)
- Specific
- Carton box of 100 staves, pallet of 25 boxes

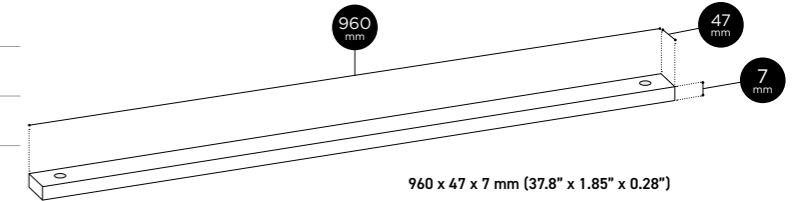

GUIDELINES FOR USE

OPTIMAL PERIOD FOR STARTING CONTACT

- White wines:**
From start of primary fermentation to maximize roundness and volume.
- Red wines:**
Before malolactic fermentation to maximize roundness and volume.

RECOMMENDED AGING TEMPERATURE

15°C (60°F) minimum with strict monitoring of microbiological conditions.

SETUP

It is recommended that the staves be attached halfway up the tank, using food-grade binding straps, or to stack them on stainless steel rods.

RECOMMENDED TIME OF CONTACT

Minimum 4 months, to be monitored by tasting.

PRACTICAL EXAMPLES OF USE

On varietal white wines (Sauvignon Blanc, Colombard) with fresh fruit profile, with the aim of adding volume and roundness to balance the acidity, without bringing any toasted oak aroma: 1 stave/hl (0.04 sq ft/gal) at the start of primary fermentation.

On fresh and full-bodied Cabernet Sauvignon with harsh tannins, aiming for roundness to coat the tannins, without modifying the typical varietal character: 2.5 staves/hl (0.10 sq ft/gal) at beginning of aging.

RECOMMENDED DOSE RATES

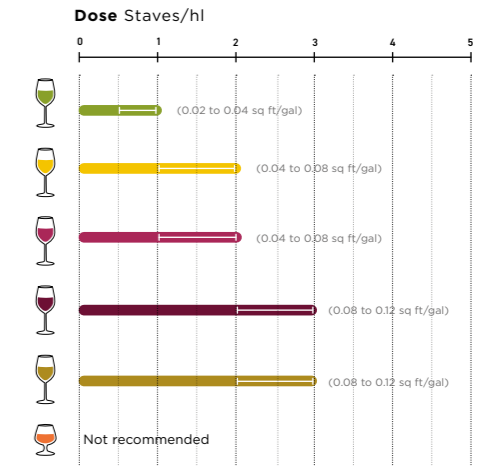

In order to help you in your winemaking decisions, please contact your Pronektar technical support

Product Stave Nektar Finesse
Dose 2,3 stv/hL
Time of contact Aging
Oak contact 4 months
Varietal Merlot
Vintage 2021
Geographic area Bordeaux

LEGEND:

- Control
- Nektar Finesse 2,3 stv/hL

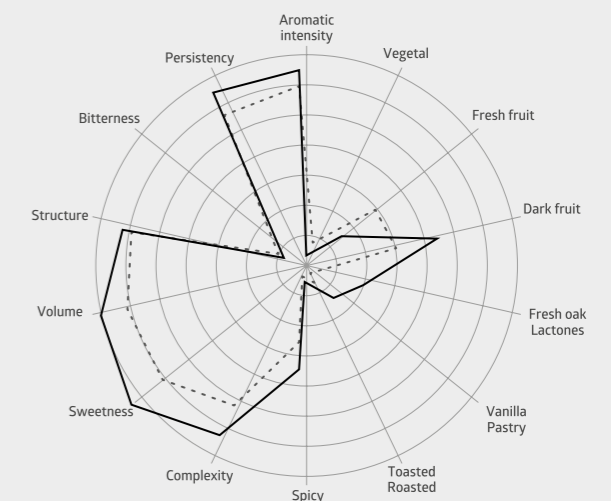

Large dimension stave
Aging over a long period



PROPERTIES

- > Wide, thick French oak staves.
- > Complex aromatic contribution while respecting the fruit.
- > Power, volume and sweetness on the palate.

OBJECTIVE: oak profile respecting the fruit, with elegance and complexity.

12
mm

TECHNICAL CHARACTERISTICS

French oak

+/- 400 g (0.88 lbs)

0.150 m² (1.63 sq ft)

Light, Medium, Medium Plus

Carton box of 40 staves,
pallet of 25 boxes

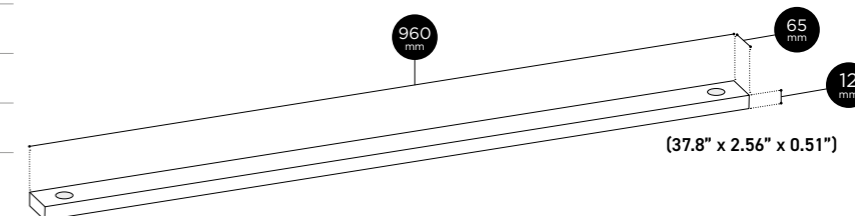

GUIDELINES FOR USE

OPTIMAL PERIOD FOR STARTING CONTACT

-White wines:

From start of primary fermentation to obtain a well-integrated oak profile and to respect the expression of the fruit.

-Red wines:

Before malolactic fermentation to obtain a more complex aromatic profile and maximum integration of the tannic structure.

RECOMMENDED AGING TEMPERATURE

15°C (60°F) minimum with strict monitoring of microbiological conditions.

SET UP

It is recommended that the staves be attached halfway up the tank, using food-grade binding straps, or to stack them on stainless steel rods.

RECOMMENDED TIME OF CONTACT

Minimum 6 months, to be monitored by tasting.

PRACTICAL EXAMPLES OF USE

On rich white varieties such as Chardonnay, aiming for a powerful, full-bodied oak profile: 2 staves/hl (0.12 sq ft/gal), 2/3 medium toast, 1/3 medium plus toast at the start of primary fermentation.

On mature, concentrated red varieties such as Syrah, aiming for a complex oak profile which respects the fruit with volume and power on the palate: 2 staves/hl (0.12 sq ft/gal), 50 % medium toast, 50% medium plus toast at the start of malolactic fermentation or at the beginning of aging.

RECOMMENDED DOSE RATES



See legend
page 19

In order to help you in your winemaking decisions, please contact your Pronektar technical support

Product Nektar XL
Oak contact Aging
Time of contact 7 months
Varietal Tannat - Cabernet Sauvignon - Cabernet Franc blend
Vintage 2009
Geographic area Sud Ouest, France

LEGEND:

- - - Essentielle French oak staves Medium + toast, dose: 2,0 staves /hL
- XL staves Medium + toast, dose 1,3 staves/hL

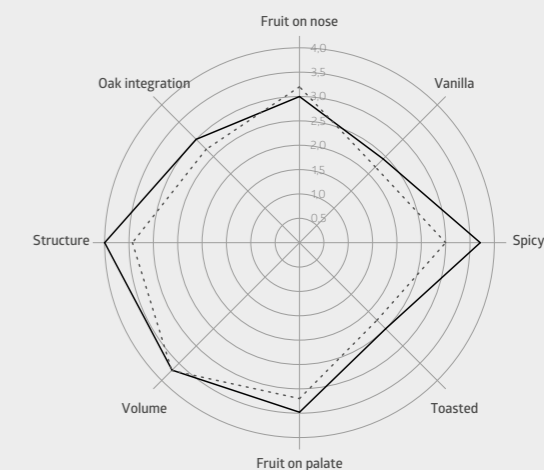

Nektar EXCLUSIVE

The super-premium stave
Dedicated to the aging of top-of-the-range wines



PROPERTIES

- > Very thick French oak staves to obtain a very gradual extraction of oak compounds.
- > Elegant and complex aromatic contribution, respecting the fruit and the terroir.
- > Gradual and elegant build-up of structure, fullness, sweetness and persistency on the palate.

OBJECTIVE: top quality oak profiles for exceptional wines coming from great terroirs and vineyards which have been prepared with great care.

17
mm

TECHNICAL CHARACTERISTICS

- French oak
- +/- 500 g (1.10 lbs)
- 0.125 m² (1.34 sq ft)
- Extended Light, Medium, Medium plus
- Carton box of 40 staves,
pallet of 25 boxes

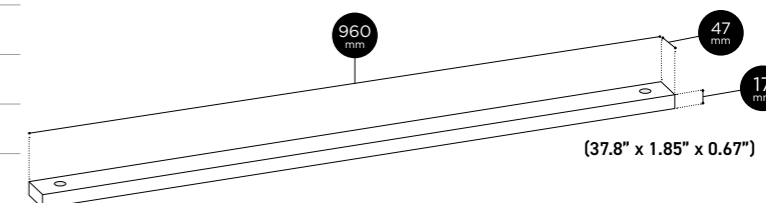

GUIDELINES FOR USE

OPTIMAL PERIOD FOR STARTING CONTACT

-White wines:

From start of primary fermentation to obtain a well-integrated oak profile and to respect the profile of the fruit.

-Red wines:

Before malolactic fermentation to obtain a more complex aromatic profile and maximum integration of the tannic structure.

RECOMMENDED AGING TEMPERATURE

15°C (60°F) minimum with strict monitoring of microbiological conditions.

SET UP

It is recommended that the staves be attached halfway up the tank, using food-grade binding straps, or to stack them on stainless steel rods.

RECOMMENDED TIME OF CONTACT

Minimum 8 months, to be monitored by tasting.

PRACTICAL EXAMPLES OF USE

On a blend of powerful and concentrated Merlot-Cabernet, aiming for a complex and elegant oak profile, respecting the terroir, similar to that obtained with traditional aging: 2 staves/hl (0.10 sq ft/gal), 20 % light toast, 50% medium toast, 30% medium plus toast at the start of malolactic fermentation.

On late harvest sweet wines, aiming for complexity and elegance, similar to that obtained with traditional aging: 2 staves/hl (0.10 sq ft/gal), 1/3 medium toast, 2/3 medium plus toast at the start of primary fermentation.

RECOMMENDED DOSE RATES



See legend page 19

In order to help you in your winemaking decisions, please contact your Pronektar technical support

Product Nektar Exclusive Medium toast
Dose 1,5 stv/hL
Oak contact Aging
Time of contact 10 months
Varietal Cabernet Sauvignon
Vintage 2014
Geographic area Bordeaux, France

LEGEND:

--- Control
 — Nektar Exclusive Medium toast



BLOCKS & STICKS

Nektar **BLOCKS**

A practical alternative to the stave,
fast acting and qualitative

Nektar **STICKS**

To refresh the oak profile of your old barrels

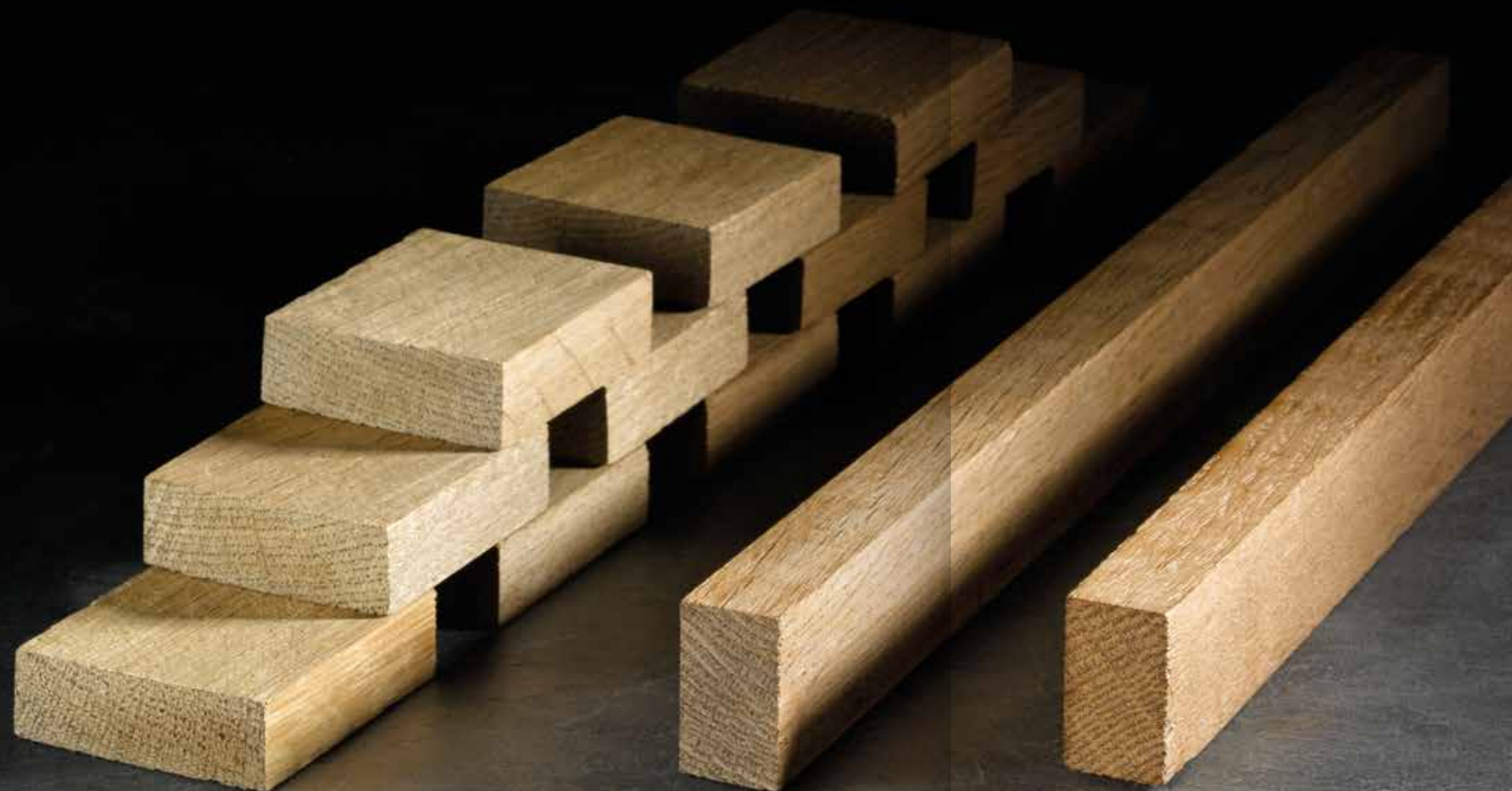

LEGEND RECOMMENDED DOSE RATES



Varietal and delicate
white and rosé wines



Powerful and concentrated red wines



Rich and concentrated
white wines



Sweet and fortified wines



Smooth and fruity red wines



Spirits

Nektar BLOCKS

A practical alternative to the stave,
fast acting and qualitative





PROPERTIES

- > Blocks in mesh bags for quick, practical and qualitative aging.
- > Elegant and complex contribution of aromas, respect of the fruit.
- > Contribution of structure on the palate, volume, sweetness and persistency.

OBJECTIVE: elegant, complex oak profile, while ensuring a practical, quick use.

TECHNICAL CHARACTERISTICS

-  French oak or American oak
-  Extended Light, Medium, Medium Plus (French oak), Specific (American oak)
-  5kg (11 lbs) mesh bag, carton box of 4 x 5 kg, pallet of 24 boxes

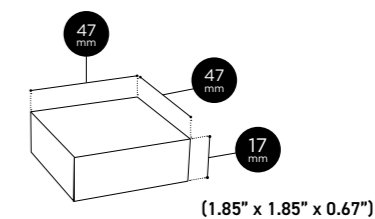

GUIDELINES FOR USE

OPTIMAL PERIOD FOR STARTING CONTACT

-White wines:

From start of primary fermentation to obtain a well-integrated oak profile and to respect the profile of the fruit.

-Red wines:

At start of primary fermentation to obtain maximum respect of the fruit profile or before malolactic fermentation for a more complex aromatic profile. In both cases maximum integration of the tannic structure will be obtained.

RECOMMENDED AGING TEMPERATURE

15°C (60°F) minimum with strict monitoring of microbiological conditions.

SET UP

It is recommended that the bags be attached halfway up the tank, using food-grade binding straps.

RECOMMENDED TIME OF CONTACT

Minimum 3 months, to be monitored by tasting.

RECOMMENDED DOSE RATES

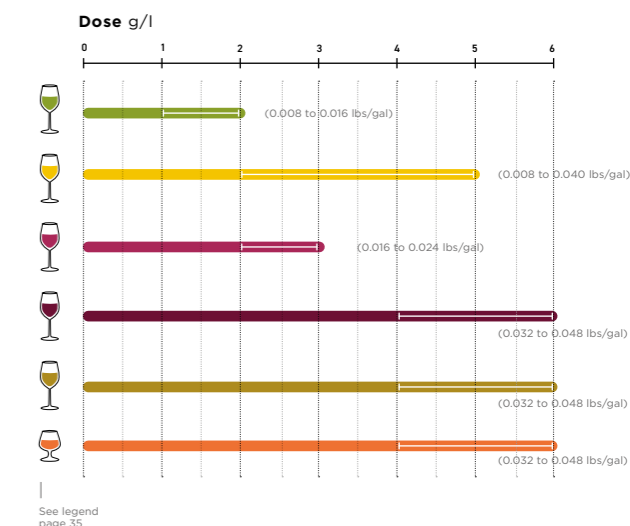

PRACTICAL EXAMPLES OF USE

On white grape varieties such as Sauvignon Blanc or Verdejo, balanced and at optimal maturity, aiming for a complex oak profile, freshness, volume, persistency and minerality: 2 g/l (0.016 lbs/gal), 30% light toast, 50% medium toast, 20% medium plus toast at the start of primary fermentation.

On a blend of mature and concentrated Merlot-Cabernet, aiming for a complex and balanced oak profile, volume, power and persistency: 4 g/l (0.032 lbs/gal), 20% light toast, 50% medium toast, 30% medium plus toast at the start of malolactic fermentation or at beginning of aging.



In order to help you in your winemaking decisions, please contact your Pronektar technical support

Product Nektar Blocks Medium + toast
Dose 3,5 g/L
Oak contact Aging
Time of contact 3,5 months
Varietal Syrah - Grenache blend
Vintage 2014
Geographic area Vallée du Rhône, France

LEGEND:

- - - Control
- Nektar Blocks Medium + toast

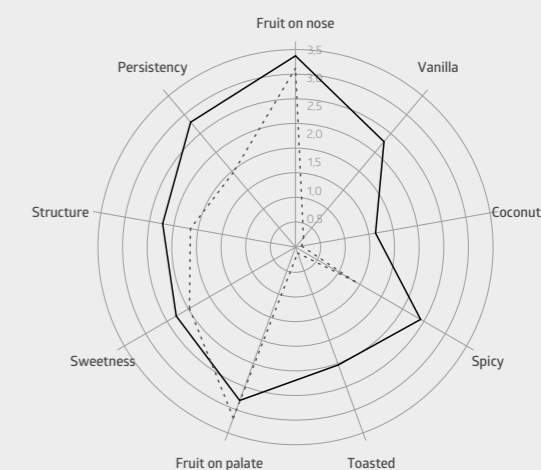

Nektar STICKS





To refresh the oak profile of your old barrels

PROPERTIES

- > A tool to place in your barrels to extend the time of their use.
- > A more intense and pleasing aromatic oak profile, masking the «old wood» notes.
- > Contribution of sweetness and volume on the palate, covering the dry tannins generated by the old barrels.

OBJECTIVE: refresh the aromas and taste of wines aged in old barrels.

TECHNICAL CHARACTERISTICS

	French oak or American oak
	+/- 350 g (0.77 lbs)
	0.1 m2 (1.08 sq ft)
	Extended Light, Medium, Medium Plus (French oak), Specific (American oak)
	Sets of sticks individually packaged, carton box of 10 sets

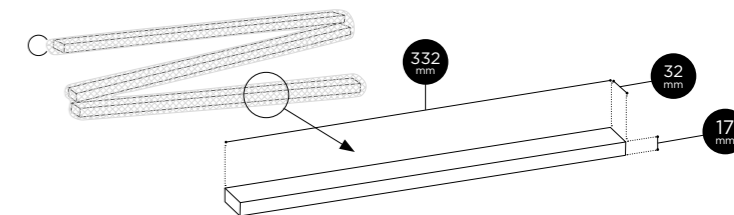

Sets of 3 sticks 332 x 32 x 17 mm (13.07" x 1.26" x 0.67") packed in mesh bag

- 3 sticks assembled in a mesh bag, separated by stainless steel staples to ensure flexibility and articulation, and to prevent the sticks from overlapping. The mesh bag will facilitate the implementation and the extraction from the barrel.

- One stainless steel ring is incorporated at each extremity, easy to open and close. This will allow to bind as many Nektar Sticks as required, in order to create a chain with personalized blend and dosage of oak.

- A stainless steel hook is delivered with every set to bind the chain of Nektar Sticks to the silicone bung.

GUIDELINES FOR USE

OPTIMAL PERIOD FOR STARTING CONTACT

-White wines:

As soon as the must is put in barrel for primary fermentation to obtain a well-integrated oak profile and to respect the fruit profile.

-Red wines:

As soon as the wine is put in barrel for better integration of the aromatic oak profile and of the tannic structure.

RECOMMENDED AGING TEMPERATURE

15°C (60°F) minimum with strict monitoring of microbiological conditions.

SET UP

Insert into the barrel through the bung hole after making space: 1 set of sticks represents approx. 0.6 liters (0.16 gallons).

RECOMMENDED TIME OF CONTACT

Minimum 8 months, to be monitored by tasting.

RECOMMENDED DOSE RATES

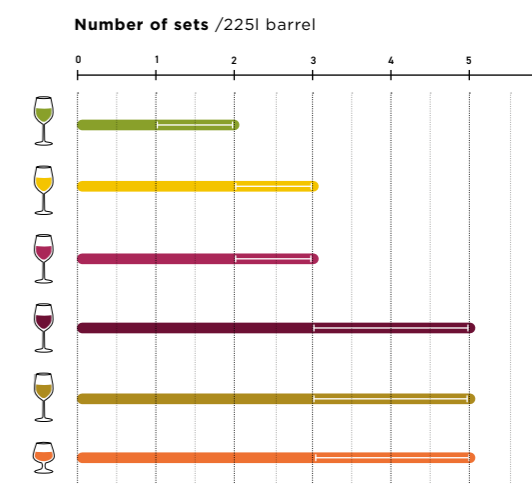

See legend page 35

PRACTICAL EXAMPLES OF USE

On a ripe and full-bodied Chardonnay fermented in 3 year-old barrels: 3 sets of Nektar Sticks French oak (1 set extended light, 1 set medium, 1 set medium plus) at the beginning of primary fermentation.

On a ripe and powerful Cabernet Sauvignon, aged in 3 year-old barrels: 3 sets of Nektar Sticks French oak (1 set medium, 2 sets medium plus) and 1 set of Nektar Sticks American oak at the beginning of aging.

In order to help you in your winemaking decisions, please contact your Pronektar technical support

Product	Nektar Sticks
Oak contact	Aging
Time of contact	11 months
Varietal	50% Merlot, 50% Cabernet Franc
Vintage	2015
Geographic area	Bordeaux Médoc
Barrel volume	225 liters
Barrel age	4 years old

LEGEND:

- 2 Nektar Sticks French Oak Medium toast and 1 Nektar Sticks French Oak Medium plus toast, dose of 4,8 g/L
- 3 Nektar Sticks French Oak Medium toast and 2 Nektar Sticks French Oak Medium plus toast, dose of 8,0 g/L

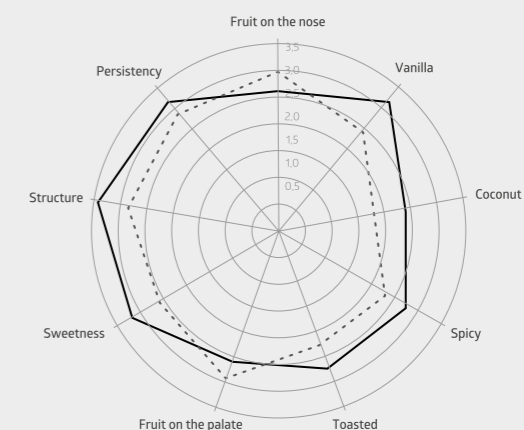

TECHNICAL DATA PRONEKTAR PRODUCTS

01. PHYSICAL CHARACTERISTICS

Botanical Species:

French oak: *Quercus petraea* (Matt.) Liebl. and *Quercus robur* L.
American oak: *Quercus alba* L.

Granulometry of fragmented products:

Granulates: 2 mm < 80% of particles < 7 mm
Chips: 7.5 x 3 x 1.5 mm < 80% of particles < 20 x 13 x 3 mm

Staves - dimensions:

Staves Essentielle, Excellence, Extreme, Nektar Pure: 960^{+/-10} x 47^{+/-2} x 7^{+/-1} mm
Staves XL: 960^{+/-10} x 65^{+/-2} x 12^{+/-1} mm
Staves Exclusive: 960^{+/-10} x 47^{+/-2} x 17,0^{+/-1} mm

Nektar Blocks - dimensions:

47 x 47 x 17 mm

Nektar Sticks - dimensions:

Assembly of 24 elements – sizes: 234 x 21 x 7 mm

Moisture content:

3^{+/-2} %

Density of products:

Granulates: 0,33^{+/-0,02}
Chips: 0,28^{+/-0,02}
Staves: 0,58^{+/-0,10}

02. USE IN ENOLOGY

Pronektar products are used during the various phases of wine making. The choice of product, the dose rate, the stage at which the product is incorporated and the time it remains in contact with the wine are defined according to the objectives the winemaker is seeking to achieve.

For more information, please contact your Pronektar® wine expert or our technical services: info@pronektar.fr
The use of oak chips in Europe is subject to regulations (EC Regulations CE 479/2008 and 606/2009).

03. HEALTH AND FOOD SAFETY

We guarantee the traceability of the products in the chips range from the forest right up to the toasting stage.

The product's batch number helps track all the data concerning the origin of the wood, its aging, as well as the production parameters.

Everyone involved in the wine making process is under the obligation of ensuring traceability and we therefore recommend that you note down the batch number of our products in the cellar register provided for this purpose.

Pronektar® regularly carries out checks on potential contamination:

- **Haloanisoles and Halophenols:** TCA, TeCA, PCA, TBA, TCP, TeCP, PCP and lindane
- **Polycyclic Aromatic Hydrocarbons:** sixteen compounds analysed including benzo(α)pyrene
- **Metal traces:** Iron, Lead, Arsenic, Cadmium and Mercury

The chemical analyses relating to the products you use are available upon request.

04. PACKAGING

The products in the chips and granulates range are packed in 10 kg polyethylene-aluminum bags. Once they are sealed the bags guarantee that the product is protected from the outside atmosphere. The bags are packed two per box. Chips are pre-packed in mesh bags. These bags hold 10kgs and are inserted into the standard polyethylene-aluminum bag. The Nektar Fresh granulates are wrapped in 10kg polyethylene-aluminum bags and packed in 300kg box pallets.

The Essentielle, Excellence, Extrême and Nektar Pure staves come in boxes of 100 units. XL and Exclusive staves come in boxes of 40 units.

Blocks are packed in 5kg infusion bags. The bags are inserted into a polyethylene-aluminum bag. The bags are packed four per box.

Sticks are assembled and then sealed in a polyethylene pack.

05. STORAGE

Please keep the product in its original packaging, away from drafts and humidity. Do not store close to volatile chemical products, solvents or any other odorous products.

CONVERSION CHART

Number of staves / hl	Type of staves	Correspondance in g/l	Correspondance in lbs/gal	Correspondance in sq ft/gal	% new oak equivalent
0,5	7 mm (Essentielle, Excellence, Pure, Extrême)	1	0.008	0.021	8
	12 mm (XL)	2	0.017	0.031	17
	17 mm (Exclusive)	2,5	0.021	0.025	18
1	7 mm (Essentielle, Excellence, Pure, Extrême)	2	0.017	0.043	17
	12 mm (XL)	4	0.033	0.062	34
	17 mm (Exclusive)	5	0.042	0.051	36
1,5	7 mm (Essentielle, Excellence, Pure, Extrême)	3	0.025	0.064	26
	12 mm (XL)	6	0.050	0.093	52
	17 mm (Exclusive)	7,5	0.063	0.076	54
2	7 mm (Essentielle, Excellence, Pure, Extrême)	4	0.033	0.085	34
	12 mm (XL)	8	0.067	0.124	69
	17 mm (Exclusive)	10	0.083	0.102	73
2,5	7 mm (Essentielle, Excellence, Pure, Extrême)	5	0.042	0.106	42
	12 mm (XL)	10	0.083	0.154	86
	17 mm (Exclusive)	12,5	0.104	0.127	91
3	7 mm (Essentielle, Excellence, Pure, Extrême)	6	0.050	0.128	51
	12 mm (XL)	12	0.100	0.185	103
	17 mm (Exclusive)	15	0.125	0.152	109
4	7 mm (Essentielle, Excellence, Pure, Extrême)	8	0.067	0.170	68
	12 mm (XL)	16	0.134	0.247	137
	17 mm (Exclusive)	20	0.167	0.203	145
5	7 mm (Essentielle, Excellence, Pure, Extrême)	10	0.083	0.213	85
	12 mm (XL)	20	0.167	0.309	172
	17 mm (Exclusive)	25	0.209	0.254	181

ADVICE ON USE OF PRODUCTS

GRANULATES

01. At the crusher



02. On the grapes during filling operation



03. In mesh bag in the must



CHIPS & BLOCKS

Hung at mid-tank

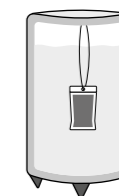

STAVES

01. On rods

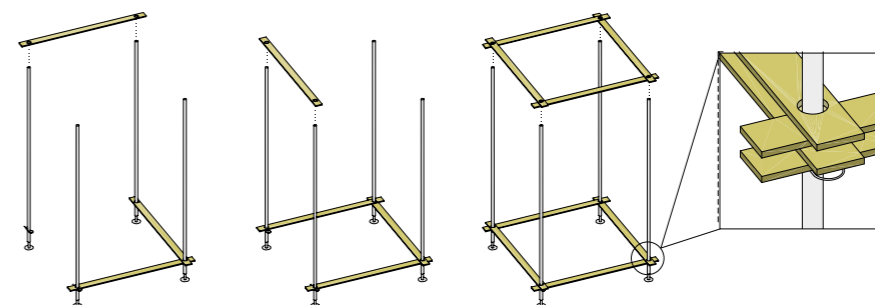

02. Suspended fan-system at mid-tank

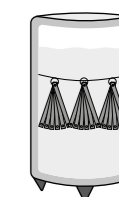

STICKS

Insert through the bung hole



